

TECHNICAL SPECIFICATIONS

Type: 751.05.01

Operating Power: 50 N

Discharge Voltage: ≥ 16 kV

Working Temperature: max.80°C

Spark Gap Distance: 6 mm

Outlet: $\text{Ø}2.1$ mm ± 0.5 mm

Weight: 28 gr.

Igniter Body: PA 6.6 30% fiberglass reinforces

GENERAL TOLERANCES

0-6 mm – ± 0.25

6-18 mm ± 0.35

18-50 mm ± 0.5

50-... mm ± 0.8

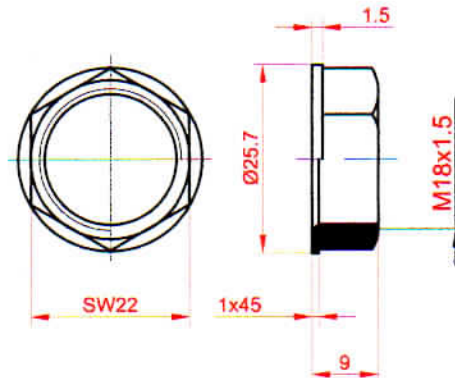
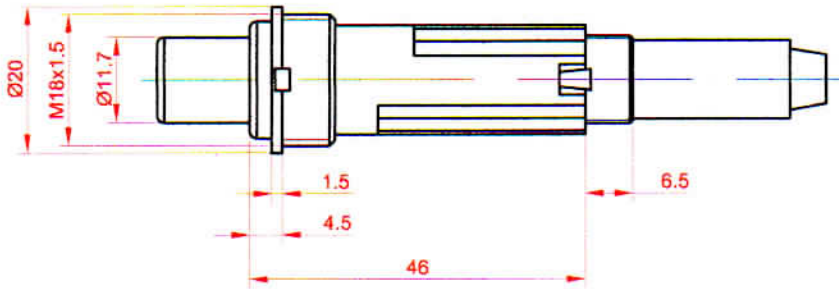
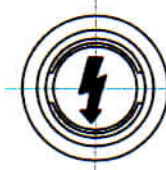
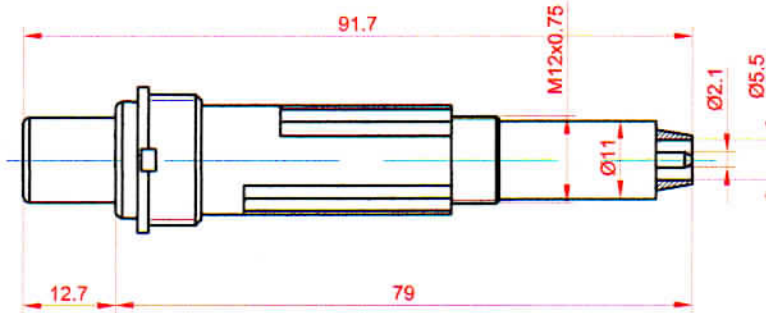

DATE : 31.10.2005

CONTROL:
E.KOCYIGIT

CUSTOMER CODE:

DRAWING : I.TASTAN

CUSTOMER NAME:

PRODUCT CODE:
751.05.01

PRODUCT NAME:
PIEZO IGNITER



TERMEL

Makina Sanayi ve Ticaret Limited Şti.

Cavusoglu mh. Selviyolu cd. No:8 Kartal
İstanbul / TÜRKİYE
Tel: +90 216 389 87 41 - 387 26 03
Fax: +90 216 374 59 21
E mail: info@termel.com.tr
Web: www.termel.com.tr