

**SERBEST TÖLERANSLAR**  
GENERAL TOLERANCES

0-6 mm	±0.1
6-30 mm	±0.2
30-120 mm	±0.3
120-... mm	±0.5

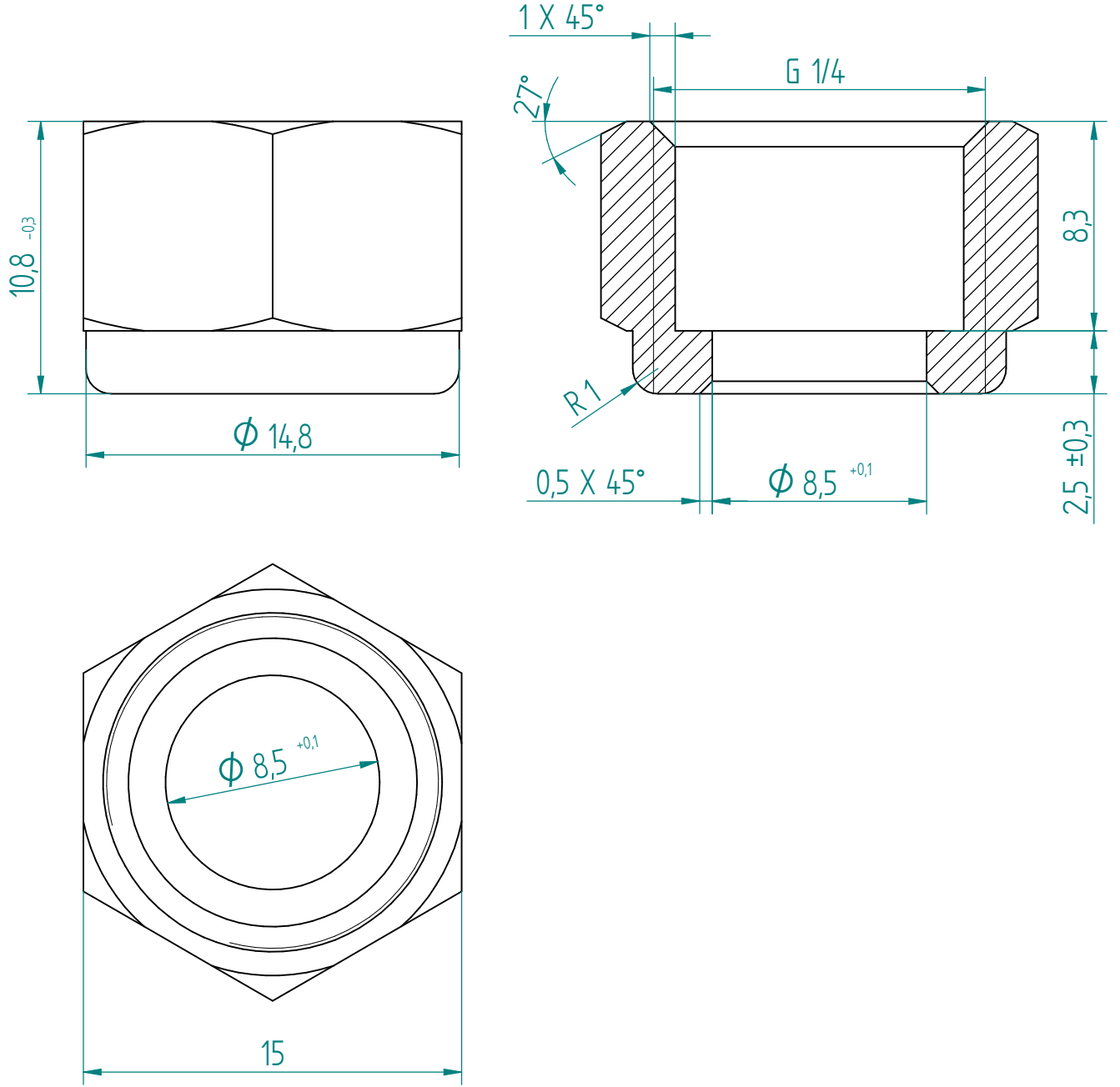

Çizimdeki tüm ölçüler mm'dir.Çizim üzerinden ölçü almayınız.  
All drawing units are mm and without scale

				<b>TARİH</b> DATE	15.03.2016	 <b>TERMEL</b> Makina Sanayi ve Ticaret Ltd. Şti. Çavuşoğlu mh. Selviyolu cd. No:8 Kartal İstanbul / TÜRKİYE Tel: +90 216 389 87 41 - 387 26 03 Fax: +90 216 374 59 21 E mail: info@termel.com.tr
				<b>ÖLÇEK</b> SCALE	-	
				<b>MALZEME</b> MATERIAL	-	
				<b>AĞIRLIK</b> WEIGHT	-	
				<b>ÇİZİM</b> DRAWING	HÜSEYİN DÜŞÜN	
				<b>KONTROL</b> CONTROL	E.KOCYIGIT	<b>ÜRÜN ADI:</b> PRODUCT NAME G <sup>1</sup> / <sub>4</sub> SOMUN
				<b>MÜŞTERİ KODU</b> CUSTOMER CODE	H40-30-120-004	
<b>SIRA NO</b> NUMBER	<b>DEĞİŞİKLİK</b> MODIFICATION	<b>İMZA</b> SIGN	<b>TARİH</b> DATE	<b>MÜŞTERİ ADI</b> CUSTOMER NAME	SER	<b>ÜRÜN KODU:</b> 94.T007 PRODUCT CODE